



Value.Quality.Service



---

**Grooving**

**2024-25**

## Grooving & Parting Tool Series Introduction

### MGEH Series

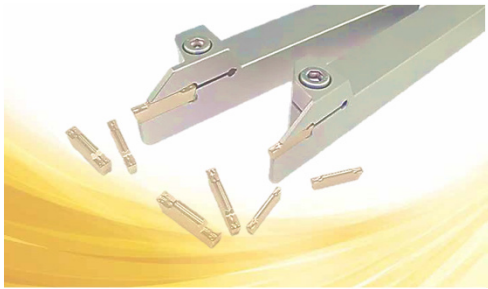

- Use MGMN200/300/400, MRMN200/300/400 inserts.
- For grooving (Depth < 20mm) of small workpieces in automatic lathe or small machine.

→ Page 2

### KGM Series

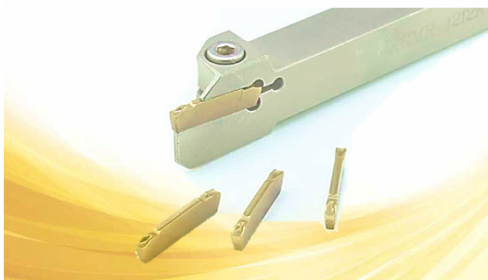

- Use GMM2020, GMM2520, GMM3020 inserts.
- For grooving (Depth < 20mm) of small workpieces in automatic lathe or small machine.

→ Page 4

### TGF Series

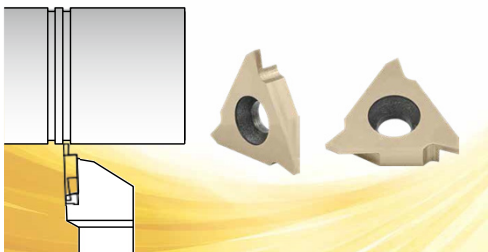

- Use TGF32 inserts for vertical grooving.
- For shallow grooving (Depth < 2.5mm) of small workpieces in automatic lathe or small machine.

→ Page 8

### TGL Series

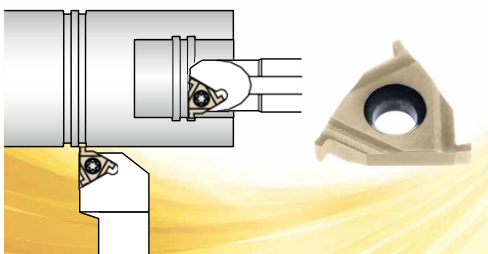

- Use TGL11 or TGL16 inserts for laydown grooving.
- For shallow grooving (Depth < 2.5mm) of small workpieces in automatic lathe or small machine.

→ Page 13

### SGIH Series

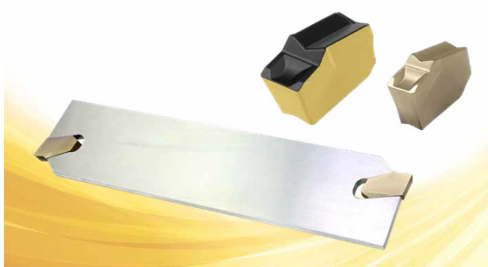

- Use TGTN0220, TGTN0310, TGTN0410 inserts.
- For parting (Depth < 40mm) of large workpieces.

→ Page 19

**MGEH Grooving Tools (Depth < 20mm)**

**Tool Holder Specifications**

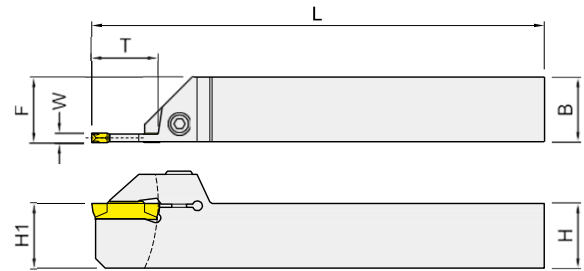
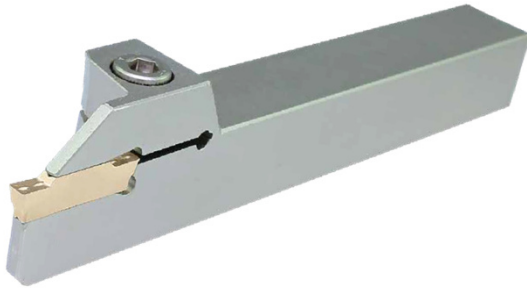

Right-hand shown

| Order Code | Description     | Dimensions (mm) |    |     |       |    |     | Inserts                | Spare Parts |
|------------|-----------------|-----------------|----|-----|-------|----|-----|------------------------|-------------|
|            |                 | H (H1)          | B  | L   | F     | T  | W   |                        |             |
| NKB101124  | MGEHR1616K2T16T | 16              | 16 | 125 | 16.25 | 16 | 2.0 | MGMN200..<br>MRMN200.. | ①           |
| NKB101125  | MGEHL1616K2T16T |                 |    |     |       |    |     |                        |             |
| NKB101126  | MGEHR2020K2T20T | 20              | 20 | 125 | 20.25 | 20 | 2.0 |                        | ②           |
| NKB101127  | MGEHL2020K2T20T |                 |    |     |       |    |     |                        |             |
| NKB101128  | MGEHR2525M2T20T | 25              | 25 | 150 | 25.25 | 20 | 2.0 |                        | ②           |
| NKB101129  | MGEHL2525M2T20T |                 |    |     |       |    |     |                        |             |
| NKB101130  | MGEHR1616K3T20T | 16              | 16 | 125 | 16.30 | 20 | 3.0 | MGMN300..<br>MRMG300.. | ①           |
| NKB101131  | MGEHL1616K3T20T |                 |    |     |       |    |     |                        |             |
| NKB101132  | MGEHR2020K3T20T | 20              | 20 | 125 | 20.30 | 20 | 3.0 |                        | ②           |
| NKB101133  | MGEHL2020K3T20T |                 |    |     |       |    |     |                        |             |
| NKB101134  | MGEHR2525M3T20T | 25              | 25 | 150 | 25.30 | 20 | 3.0 |                        | ②           |
| NKB100028  | MGEHR2525M4T20T |                 |    |     |       |    |     |                        |             |

| Spare Parts | Screw    | Wrench |
|-------------|----------|--------|
| ①           | IHTMT520 | IETL25 |
| ②           | IHTMT525 | IETL25 |

**MGEH Grooving Tools (Depth < 20mm)**

**Insert Specifications**

| Insert         | Dimensions (mm) |            |           |            |             |
|----------------|-----------------|------------|-----------|------------|-------------|
|                | w               | r          | l         | h          | m           |
| <b>MGMN200</b> | <b>2.0</b>      | <b>0.2</b> | <b>16</b> | <b>3.5</b> | <b>1.60</b> |
| <b>MGMN300</b> | <b>3.0</b>      | <b>0.4</b> | <b>21</b> | <b>4.8</b> | <b>2.35</b> |
| <b>MGMN400</b> | <b>4.0</b>      | <b>0.4</b> | <b>21</b> | <b>4.8</b> | <b>3.30</b> |
| <b>MRMN200</b> | <b>2.0</b>      | <b>1.0</b> | <b>16</b> | <b>3.5</b> | <b>1.60</b> |
| <b>MRMN300</b> | <b>3.0</b>      | <b>1.5</b> | <b>21</b> | <b>4.8</b> | <b>2.35</b> |
| <b>MRMN400</b> | <b>4.0</b>      | <b>2.0</b> | <b>21</b> | <b>4.8</b> | <b>3.30</b> |

| Chipbreaker |                     |
|-------------|---------------------|
| GM          | For general cutting |

**Insert Description**

| Inserts | Order Code | Description        | Working Material |   |   |   |   |   |
|---------|------------|--------------------|------------------|---|---|---|---|---|
|         |            |                    | P                | M | K | N | S | H |
|         | NKB101000  | MGMN200 GS IL67UYP | ●                | ● | ● |   | ● | ● |
|         | NKB101001  | MGMN200 GS IL57UYP | ●                | ● | ● |   | ○ |   |
|         | NKB101002  | MGMN300 GM IL67UYP | ●                | ● | ● |   | ● | ● |
|         | NKB101003  | MGMN300 GM IL57UYP | ●                | ● | ● |   | ○ |   |
|         | NKB101004  | MGMN400 GM IL67UYP | ●                | ● | ● |   | ● | ● |
|         | NKB101005  | MGMN400 GM IL57UYP | ●                | ● | ● |   | ○ |   |
|         | NKB101006  | MRMN200 GM IL67UYP | ●                | ● | ● |   | ● | ● |
|         | NKB101007  | MRMN200 GM IL57UYP | ●                | ● | ● |   | ○ |   |
|         | NKB101008  | MRMN300 GM IL67UYP | ●                | ● | ● |   | ● | ● |
|         | NKB101009  | MRMN300 GM IL57UYP | ●                | ● | ● |   | ○ |   |
|         | NKB101010  | MRMN400 GM IL67UYP | ●                | ● | ● |   | ● | ● |
|         | NKB101011  | MRMN400 GM IL57UYP | ●                | ● | ● |   | ○ |   |

\* IL67UYP for General cutting.  
 IL57UYP for Interrupted cutting.

**KGM Grooving Tools (Depth < 20mm)**

**Tool Holder Specifications**

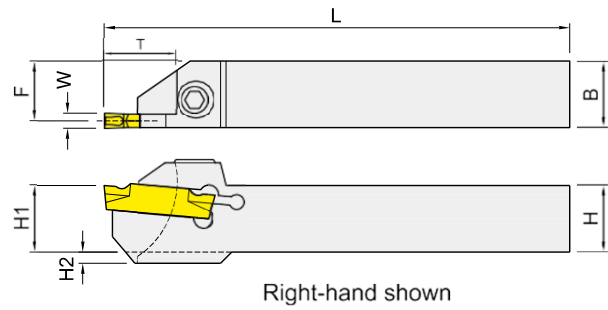



| Order Code | Description     | Dimensions (mm) |    |     |      |    |    | W (mm) |     | Inserts   | Spare Parts |
|------------|-----------------|-----------------|----|-----|------|----|----|--------|-----|-----------|-------------|
|            |                 | H (H1)          | B  | L   | F    | T  | H2 | min    | max |           |             |
| NKB101136  | KGMR1212K1.5L10 | 12              | 12 | 125 | 11.4 | 10 | 2  | 1.5    | 2.0 | GMM2020.. | ①           |
| NKB101137  | KGML1212K1.5L10 |                 |    |     |      |    |    |        |     |           |             |
| NKB101138  | KGMR1616K1.5L10 | 16              | 16 | 125 | 15.4 | 10 | -  | 1.5    | 2.0 |           | ②           |
| NKB101139  | KGML1616K1.5L10 |                 |    |     |      |    |    |        |     |           |             |
| NKB101140  | KGMR2020K1.5L10 | 20              | 20 | 125 | 19.4 | 10 | -  | 1.5    | 2.0 |           | ③           |
| NKB101141  | KGML2020K1.5L10 |                 |    |     |      |    |    |        |     |           |             |
| NKB101142  | KGMR2525M1.5L10 | 25              | 25 | 150 | 24.4 | 10 | -  | 1.5    | 2.0 |           | ③           |
| NKB101143  | KGML2525M1.5L10 |                 |    |     |      |    |    |        |     |           |             |

| Spare Parts | Screw    | Wrench |
|-------------|----------|--------|
| ①           | IHTM416  | IPL30  |
| ②           | IHTMT520 | IETL25 |
| ③           | IHTMT525 | IETL25 |



## KGM Grooving Tools (Depth &lt; 20mm)

| Order Code | Description    | Dimensions (mm) |    |     |      |    |    | W (mm) |     | Inserts                             | Spare part |
|------------|----------------|-----------------|----|-----|------|----|----|--------|-----|-------------------------------------|------------|
|            |                | H (H1)          | B  | L   | F    | T  | H2 | min    | max |                                     |            |
| NKB101144  | KGMR1212K2TL10 | 12              | 12 | 125 | 11.1 | 10 | 2  | 2.0    | 3.0 | GMM2020..<br>GMM2520..<br>GMM3020.. | ①          |
| NKB101145  | KGML1212K2TL10 |                 |    |     |      |    |    |        |     |                                     | ②          |
| NKB101146  | KGMR1616K2TL10 | 16              | 16 | 125 | 15.1 | 10 | -  | 2.0    | 3.0 |                                     | ③          |
| NKB101147  | KGML1616K2TL10 |                 |    |     |      |    |    |        |     |                                     | ③          |
| NKB101148  | KGMR2020K2TL10 | 20              | 20 | 125 | 19.1 | 10 | -  | 2.0    | 3.0 |                                     | ④          |
| NKB101149  | KGML2020K2TL10 |                 |    |     |      |    |    |        |     |                                     | ④          |
| NKB101150  | KGMR2525M2TL10 | 25              | 25 | 150 | 24.1 | 10 | -  | 2.0    | 3.0 |                                     | ⑤          |
| NKB101151  | KGML2525M2TL10 |                 |    |     |      |    |    |        |     |                                     | ⑤          |
| NKB101152  | KGMR1212K2TL13 | 12              | 12 | 125 | 11.1 | 13 | 3  | 2.0    | 3.0 |                                     | ⑥          |
| NKB101153  | KGML1212K2TL13 |                 |    |     |      |    |    |        |     |                                     | ⑥          |
| NKB101154  | KGMR1616K2TL13 | 16              | 16 | 125 | 15.1 | 13 | -  | 2.0    | 3.0 |                                     | ⑦          |
| NKB101155  | KGML1616K2TL13 |                 |    |     |      |    |    |        |     |                                     | ⑦          |
| NKB101156  | KGMR2020K2TL13 | 20              | 20 | 125 | 19.1 | 13 | -  | 2.0    | 3.0 |                                     | ⑧          |
| NKB101157  | KGML2020K2TL13 |                 |    |     |      |    |    |        |     |                                     | ⑧          |
| NKB101158  | KGMR2525M2TL13 | 25              | 25 | 150 | 24.1 | 13 | -  | 2.0    | 3.0 |                                     | ⑨          |
| NKB101159  | KGML2525M2TL13 |                 |    |     |      |    |    |        |     |                                     | ⑨          |
| NKB101160  | KGMR1212K2TL17 | 12              | 12 | 125 | 11.1 | 17 | 4  | 2.0    | 3.0 |                                     | ⑩          |
| NKB101161  | KGML1212K2TL17 |                 |    |     |      |    |    |        |     |                                     | ⑩          |
| NKB101162  | KGMR1616K2TL17 | 16              | 16 | 125 | 15.1 | 17 | -  | 2.0    | 3.0 |                                     | ⑪          |
| NKB101163  | KGML1616K2TL17 |                 |    |     |      |    |    |        |     |                                     | ⑪          |
| NKB101164  | KGMR2020K2TL17 | 20              | 20 | 125 | 19.1 | 17 | -  | 2.0    | 3.0 | ⑫                                   |            |
| NKB101165  | KGML2020K2TL17 |                 |    |     |      |    |    |        |     | ⑫                                   |            |
| NKB101166  | KGMR2525M2TL17 | 25              | 25 | 150 | 24.1 | 17 | -  | 2.0    | 3.0 | ⑬                                   |            |
| NKB101167  | KGML2525M2TL17 |                 |    |     |      |    |    |        |     | ⑬                                   |            |

| Spare Parts |  Screw |  Wrench |
|-------------|-------------------------------------------------------------------------------------------|----------------------------------------------------------------------------------------------|
| ①           | IHTM416                                                                                   | IPL30                                                                                        |
| ②           | IHTMT520                                                                                  | IETL25                                                                                       |
| ③           | IHTMT525                                                                                  | IETL25                                                                                       |
| ④           | IHTM420                                                                                   | IPL30                                                                                        |

**KGM Grooving Tools (Depth < 20mm)**

| Order Code | Description    | Dimensions (mm) |    |     |      |    |    | W (mm) |     | Inserts   | Spare Parts |
|------------|----------------|-----------------|----|-----|------|----|----|--------|-----|-----------|-------------|
|            |                | H (H1)          | B  | L   | F    | T  | H2 | min    | max |           |             |
| NKB101168  | KGMR1616K3TL16 | 16              | 16 | 125 | 14.8 | 16 | -  | 3.0    | 4.0 | GMM3020.. | ①           |
| NKB101169  | KGML1616K3TL16 |                 |    |     |      |    |    |        |     |           | ②           |
| NKB101170  | KGMR2020K3TL16 | 20              | 20 | 125 | 18.8 | 16 | -  | 3.0    | 4.0 |           | ②           |
| NKB101171  | KGML2020K3TL16 |                 |    |     |      |    |    |        |     |           | ②           |
| NKB101172  | KGMR2525M3TL16 | 25              | 25 | 150 | 23.8 | 16 | -  | 3.0    | 4.0 |           | ②           |
| NKB101173  | KGML2525M3TL16 |                 |    |     |      |    |    |        |     |           | ②           |
| NKB101174  | KGMR1616K3TL20 | 16              | 16 | 125 | 14.8 | 20 | 4  | 3.0    | 4.0 |           | ②           |
| NKB101175  | KGML1616K3TL20 |                 |    |     |      |    |    |        |     |           | ②           |
| NKB101176  | KGMR2020K3TL20 | 20              | 20 | 125 | 18.8 | 20 | -  | 3.0    | 4.0 |           | ②           |
| NKB101177  | KGML2020K3TL20 |                 |    |     |      |    |    |        |     |           | ②           |
| NKB101178  | KGMR2525M3TL20 | 25              | 25 | 150 | 23.8 | 20 | -  | 3.0    | 4.0 |           | ②           |
| NKB101179  | KGML2525M3TL20 |                 |    |     |      |    |    |        |     |           | ②           |
| NKB101180  | KGMR3232P3TL20 | 32              | 32 | 170 | 30.8 | 20 | -  | 3.0    | 4.0 | ②         |             |

| Spare Parts |  Screw |  Wrench |
|-------------|-------------------------------------------------------------------------------------------|----------------------------------------------------------------------------------------------|
| ①           | IHTMT520                                                                                  | IETL25                                                                                       |
| ②           | IHTMT525                                                                                  | IETL25                                                                                       |

**KGM Grooving Tools (Depth < 20mm)**

**Insert Specifications**

| Insert     | Dimensions (mm) |      |    |     |     |     | Fig. | Chipbreaker |                       |
|------------|-----------------|------|----|-----|-----|-----|------|-------------|-----------------------|
|            | w               | r    | l  | h   | m   | k°  |      | RM          | For high feed cutting |
| GMM2020    | 2.0             | 0.20 | 20 | 4.3 | 1.5 | -   | 1    |             |                       |
| GMM2020R06 | 2.0             | 0.20 | 20 | 4.3 | 1.5 | 6°  | 2    |             |                       |
| GMM2020R15 | 2.0             | 0.05 | 20 | 4.3 | 1.5 | 15° | 2    |             |                       |
| GMM2020L15 | 2.0             | 0.05 | 20 | 4.3 | 1.5 | 15° | 3    |             |                       |
| GMM2520    | 2.5             | 0.20 | 20 | 4.3 | 1.9 | -   | 1    |             |                       |
| GMM2520R06 | 2.5             | 0.20 | 20 | 4.3 | 1.9 | 6°  | 2    |             |                       |
| GMM2520R15 | 2.5             | 0.05 | 20 | 4.3 | 1.9 | 15° | 2    |             |                       |
| GMM2520L15 | 2.5             | 0.05 | 20 | 4.3 | 1.9 | 15° | 3    |             |                       |
| GMM3020    | 3.0             | 0.25 | 20 | 4.3 | 2.3 | -   | 1    |             |                       |
| GMM3020R06 | 3.0             | 0.25 | 20 | 4.3 | 2.3 | 6°  | 2    |             |                       |
| GMM3020R15 | 3.0             | 0.05 | 20 | 4.3 | 2.3 | 15° | 2    |             |                       |
| GMM3020L15 | 3.0             | 0.05 | 20 | 4.3 | 2.3 | 15° | 3    |             |                       |

**Insert Description**

| Insert | Order Code | Description           | Working Material |   |   |   |   |   |
|--------|------------|-----------------------|------------------|---|---|---|---|---|
|        |            |                       | P                | M | K | N | S | H |
|        | NKB101012  | GMM2020 RM IL67UYP    | ●                | ● | ● |   | ● | ● |
|        | NKB101013  | GMM2020 RM IL57UYP    | ●                | ● | ● |   | ○ |   |
|        | NKB101014  | GMM2520 RM IL67UYP    | ●                | ● | ● |   | ● | ● |
|        | NKB101015  | GMM3020 RM IL67UYP    | ●                | ● | ● |   | ● | ● |
|        | NKB101016  | GMM2020R06 RM IL67UYP | ●                | ● | ● |   | ● | ● |
|        | NKB101017  | GMM2020R06 RM IL57UYP | ●                | ● | ● |   | ○ |   |
|        | NKB101018  | GMM2520R06 RM IL67UYP | ●                | ● | ● |   | ● | ● |
|        | NKB101019  | GMM3020R06 RM IL67UYP | ●                | ● | ● |   | ● | ● |
|        | NKB101020  | GMM2020R15 RM IL67UYP | ●                | ● | ● |   | ● | ● |
|        | NKB101021  | GMM2020L15 RM IL67UYP | ●                | ● | ● |   | ● | ● |
|        | NKB101022  | GMM2020R15 RM IL57UYP | ●                | ● | ● |   | ○ |   |
|        | NKB101023  | GMM2020L15 RM IL57UYP | ●                | ● | ● |   | ○ |   |
|        | NKB101024  | GMM2520R15 RM IL67UYP | ●                | ● | ● |   | ● | ● |
|        | NKB101025  | GMM2520L15 RM IL67UYP | ●                | ● | ● |   | ● | ● |
|        | NKB101026  | GMM3020R15 RM IL67UYP | ●                | ● | ● |   | ○ | ● |
|        | NKB101027  | GMM3020L15 RM IL67UYP | ●                | ● | ● |   | ○ | ● |

\* IL67UYP for General cutting.  
IL57UYP for Interrupted cutting.



**TGF Shallow Grooving Tools (Vertical , Depth < 2.5mm)**

**Tool Holder Specifications**

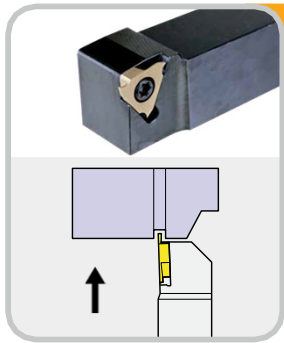

**KTGF**

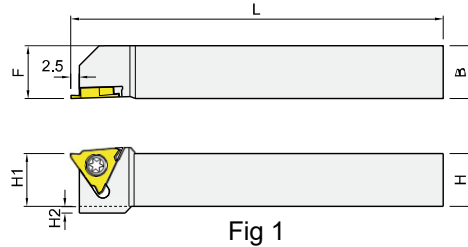

Fig 1

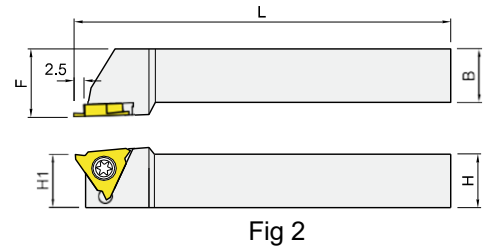
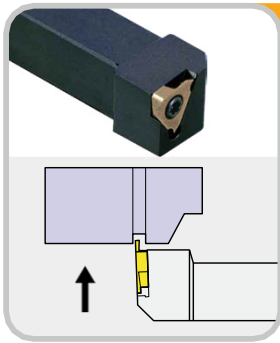

Fig 2

Right-hand shown

| Order Code | Description   | Dimensions (mm) |    |     |    |    | Insert           | Screw    | Wrench | Fig |
|------------|---------------|-----------------|----|-----|----|----|------------------|----------|--------|-----|
|            |               | H(H1)           | B  | L   | H2 | F  |                  |          |        |     |
| NKB101181  | KTGFR1010K16F | 10              | 10 | 125 | 4  | 10 | TGF32R<br>TGF32L | IMS4009A | ITK15  | 1   |
| NKB101182  | KTGFL1010K16F |                 |    |     |    |    |                  |          |        |     |
| NKB101183  | KTGFR1012K16F | 10              | 12 | 125 | 2  | 12 |                  |          |        |     |
| NKB101184  | KTGFR1212K16F | 12              | 12 | 125 | 2  | 12 |                  |          |        |     |
| NKB101185  | KTGFL1212K16F |                 |    |     |    |    |                  |          |        |     |
| NKB101186  | KTGFR1616K16F | 16              | 16 | 125 | -  | 16 |                  |          |        |     |
| NKB101187  | KTGFL1616K16F |                 |    |     |    |    |                  |          |        |     |
| NKB101188  | KTGFR2020K16F | 20              | 20 | 125 | -  | 20 | TGF32R           | IMS4011A | ITK15  | 2   |
| NKB101189  | KTGFR1616K16  | 16              | 16 | 125 | -  | 20 | TGF32R<br>TGF32L |          |        |     |
| NKB101190  | KTGFL1616K16  |                 |    |     |    |    |                  |          |        |     |
| NKB101191  | KTGFR2020K16  | 20              | 20 | 125 | -  | 25 |                  |          |        |     |
| NKB101192  | KTGFL2020K16  |                 |    |     |    |    |                  |          |        |     |
| NKB101193  | KTGFR2525M16  | 25              | 25 | 150 | -  | 32 |                  |          |        |     |
| NKB100027  | KTGFL2525M16  |                 |    |     |    |    |                  |          |        |     |



**TGF Shallow Grooving Tools (Vertical , Depth < 2.5mm)**

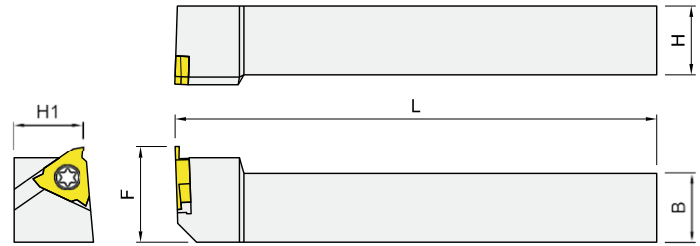

**KTGFS**



Left-hand shown

| Order Code | Description   | Dimensions (mm) |    |     |    | Insert | Screw<br> | Wrench<br> |
|------------|---------------|-----------------|----|-----|----|--------|----------------------------------------------------------------------------------------------|-----------------------------------------------------------------------------------------------|
|            |               | H(H1)           | B  | L   | F  |        |                                                                                              |                                                                                               |
| NKB101195  | KTGFSL1616K16 | 16              | 16 | 125 | 22 | TGF32R | IMS4009A                                                                                     | ITK15                                                                                         |
| NKB101196  | KTGFSL2020K16 | 20              | 20 | 125 | 26 |        |                                                                                              |                                                                                               |

**TGF Shallow Grooving Tools (Vertical , Depth < 2.5mm)**

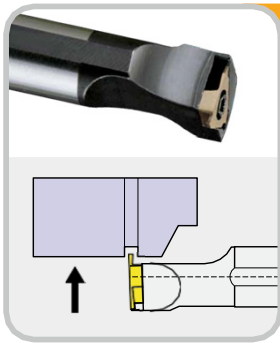

**Tool Holder Specifications**

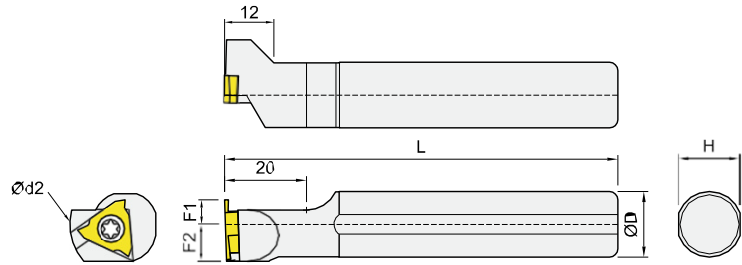

**KTGFL**



Left-hand shown

| Order Code | Description | Dimensions (mm) |     |    |    |    |    | Insert | Screw  | Wrench  |
|------------|-------------|-----------------|-----|----|----|----|----|--------|-------------------------------------------------------------------------------------------|--------------------------------------------------------------------------------------------|
|            |             | D               | L   | H  | F1 | F2 | d2 |        |                                                                                           |                                                                                            |
| NKB101197  | S16HKTGFL16 | 16              | 100 | 15 | 6  | 9  | 27 | TGF32R | IMS4009A                                                                                  | ITK15                                                                                      |

**Recommended Cutting Conditions**

| Working Material           | Vc (m/min) | fr (mm/rev) |
|----------------------------|------------|-------------|
| Carbon Steel / Alloy Steel | 50 ~ 200   | 0.02 ~ 0.10 |
| Stainless Steel            | 50 ~ 200   | 0.02 ~ 0.10 |
| Cast Iron                  | 50 ~ 200   | 0.02 ~ 0.10 |
| Aluminum Alloy             | 200 ~ 300  | 0.05 ~ 0.15 |
| High Temperature Alloy     | 80 ~ 120   | 0.03 ~ 0.07 |
| Hardened Steel             | 80 ~ 120   | 0.03 ~ 0.07 |

**KTGF Shallow Grooving Tools (Vertical , Depth < 2.5mm)**

**Insert Description**

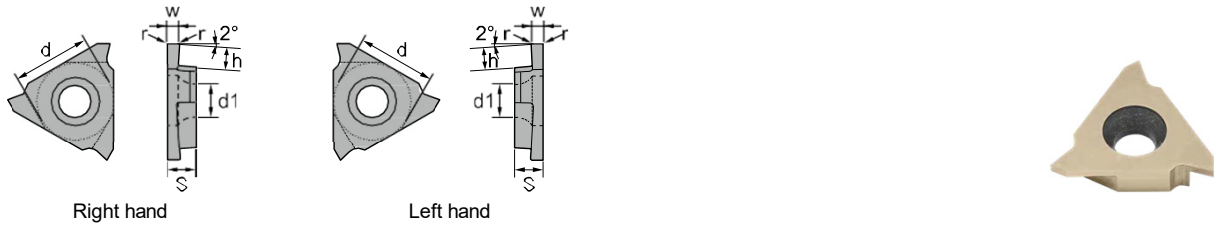

| Order Code | Description       | Dimensions (mm) |     |      |      |       |     | Max Depth of Cut |      | Working Material |   |   |   |   |   |
|------------|-------------------|-----------------|-----|------|------|-------|-----|------------------|------|------------------|---|---|---|---|---|
|            |                   | w               | h   | r    | S    | d     | d1  | O.D.             | I.D. | P                | M | K | N | S | H |
| NKB101028  | TGF32R033 IL4025P | 0.33            | 1.0 | 0.05 | 3.18 | 9.525 | 4.4 | 0.8              | 0.5  | ●                | ● | ● |   | ○ | ○ |
| NKB101029  | TGF32L033 IL4025P | 0.33            | 1.0 | 0.05 | 3.18 | 9.525 | 4.4 | 0.8              | 0.5  | ●                | ● | ● |   | ○ | ○ |
| NKB101030  | TGF32R050 IL4025P | 0.50            | 1.4 | 0.05 | 3.18 | 9.525 | 4.4 | 1.2              | 0.8  | ●                | ● | ● |   | ○ | ○ |
| NKB101031  | TGF32L050 IL4025P | 0.50            | 1.4 | 0.05 | 3.18 | 9.525 | 4.4 | 1.2              | 0.8  | ●                | ● | ● |   | ○ | ○ |
| NKB101032  | TGF32R075 IL4025P | 0.75            | 2.5 | 0.1  | 3.18 | 9.525 | 4.4 | 2.0              | 1.5  | ●                | ● | ● |   | ○ | ○ |
| NKB101033  | TGF32L075 IL4025P | 0.75            | 2.5 | 0.1  | 3.18 | 9.525 | 4.4 | 2.0              | 1.5  | ●                | ● | ● |   | ○ | ○ |
| NKB101034  | TGF32R095 IL4025P | 0.95            | 2.5 | 0.1  | 3.18 | 9.525 | 4.4 | 2.0              | 1.5  | ●                | ● | ● |   | ○ | ○ |
| NKB101035  | TGF32L095 IL4025P | 0.95            | 2.5 | 0.1  | 3.18 | 9.525 | 4.4 | 2.0              | 1.5  | ●                | ● | ● |   | ○ | ○ |
| NKB101036  | TGF32R100 IL4025P | 1.00            | 2.5 | 0.1  | 3.18 | 9.525 | 4.4 | 2.0              | 1.5  | ●                | ● | ● |   | ○ | ○ |
| NKB101037  | TGF32L100 IL4025P | 1.00            | 2.5 | 0.1  | 3.18 | 9.525 | 4.4 | 2.0              | 1.5  | ●                | ● | ● |   | ○ | ○ |
| NKB101038  | TGF32R110 IL4025P | 1.10            | 2.5 | 0.1  | 3.18 | 9.525 | 4.4 | 2.0              | 1.5  | ●                | ● | ● |   | ○ | ○ |
| NKB101039  | TGF32L110 IL4025P | 1.10            | 2.5 | 0.1  | 3.18 | 9.525 | 4.4 | 2.0              | 1.5  | ●                | ● | ● |   | ○ | ○ |
| NKB101040  | TGF32R125 IL4025P | 1.25            | 2.5 | 0.1  | 3.18 | 9.525 | 4.4 | 2.0              | 1.5  | ●                | ● | ● |   | ○ | ○ |
| NKB101041  | TGF32L125 IL4025P | 1.25            | 2.5 | 0.1  | 3.18 | 9.525 | 4.4 | 2.0              | 1.5  | ●                | ● | ● |   | ○ | ○ |
| NKB101042  | TGF32R135 IL4025P | 1.35            | 2.5 | 0.1  | 3.18 | 9.525 | 4.4 | 2.0              | 1.5  | ●                | ● | ● |   | ○ | ○ |
| NKB101043  | TGF32L135 IL4025P | 1.35            | 2.5 | 0.1  | 3.18 | 9.525 | 4.4 | 2.0              | 1.5  | ●                | ● | ● |   | ○ | ○ |
| NKB101044  | TGF32R145 IL4025P | 1.45            | 2.5 | 0.1  | 3.18 | 9.525 | 4.4 | 2.0              | 1.5  | ●                | ● | ● |   | ○ | ○ |
| NKB101045  | TGF32L145 IL4025P | 1.45            | 2.5 | 0.1  | 3.18 | 9.525 | 4.4 | 2.0              | 1.5  | ●                | ● | ● |   | ○ | ○ |
| NKB101046  | TGF32R150 IL4025P | 1.50            | 2.5 | 0.1  | 3.18 | 9.525 | 4.4 | 2.0              | 1.5  | ●                | ● | ● |   | ○ | ○ |
| NKB101047  | TGF32L150 IL4025P | 1.50            | 2.5 | 0.1  | 3.18 | 9.525 | 4.4 | 2.0              | 1.5  | ●                | ● | ● |   | ○ | ○ |
| NKB101048  | TGF32R165 IL4025P | 1.65            | 2.5 | 0.1  | 3.18 | 9.525 | 4.4 | 2.0              | 1.5  | ●                | ● | ● |   | ○ | ○ |
| NKB101049  | TGF32L165 IL4025P | 1.65            | 2.5 | 0.1  | 3.18 | 9.525 | 4.4 | 2.0              | 1.5  | ●                | ● | ● |   | ○ | ○ |
| NKB101050  | TGF32R175 IL4025P | 1.75            | 2.5 | 0.1  | 3.18 | 9.525 | 4.4 | 2.0              | 1.5  | ●                | ● | ● |   | ○ | ○ |
| NKB101051  | TGF32L175 IL4025P | 1.75            | 2.5 | 0.1  | 3.18 | 9.525 | 4.4 | 2.0              | 1.5  | ●                | ● | ● |   | ○ | ○ |
| NKB101052  | TGF32R180 IL4025P | 1.80            | 2.5 | 0.1  | 3.18 | 9.525 | 4.4 | 2.0              | 1.5  | ●                | ● | ● |   | ○ | ○ |
| NKB101053  | TGF32L180 IL4025P | 1.80            | 2.5 | 0.1  | 3.18 | 9.525 | 4.4 | 2.0              | 1.5  | ●                | ● | ● |   | ○ | ○ |
| NKB101054  | TGF32R185 IL4025P | 1.85            | 2.5 | 0.1  | 3.18 | 9.525 | 4.4 | 2.0              | 1.5  | ●                | ● | ● |   | ○ | ○ |
| NKB101055  | TGF32L185 IL4025P | 1.85            | 2.5 | 0.1  | 3.18 | 9.525 | 4.4 | 2.0              | 1.5  | ●                | ● | ● |   | ○ | ○ |
| NKB101056  | TGF32R195 IL4025P | 1.95            | 2.5 | 0.1  | 3.18 | 9.525 | 4.4 | 2.0              | 1.5  | ●                | ● | ● |   | ○ | ○ |
| NKB101057  | TGF32L195 IL4025P | 1.95            | 2.5 | 0.1  | 3.18 | 9.525 | 4.4 | 2.0              | 1.5  | ●                | ● | ● |   | ○ | ○ |
| NKB101058  | TGF32R200 IL4025P | 2.00            | 2.5 | 0.1  | 3.18 | 9.525 | 4.4 | 2.0              | 1.5  | ●                | ● | ● |   | ○ | ○ |
| NKB101059  | TGF32L200 IL4025P | 2.00            | 2.5 | 0.1  | 3.18 | 9.525 | 4.4 | 2.0              | 1.5  | ●                | ● | ● |   | ○ | ○ |
| NKB101060  | TGF32R250 IL4025P | 2.50            | 2.5 | 0.1  | 3.18 | 9.525 | 4.4 | 2.0              | 1.5  | ●                | ● | ● |   | ○ | ○ |
| NKB101061  | TGF32L250 IL4025P | 2.50            | 2.5 | 0.1  | 3.18 | 9.525 | 4.4 | 2.0              | 1.5  | ●                | ● | ● |   | ○ | ○ |

※ To choose IL90U(uncoating) for **N** material machining.

**KTGF Shallow Grooving Tools (Vertical , Depth < 2.5mm)**

**Insert Description**

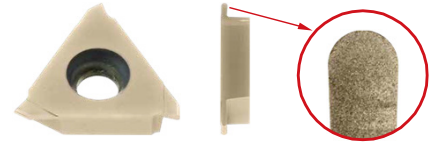
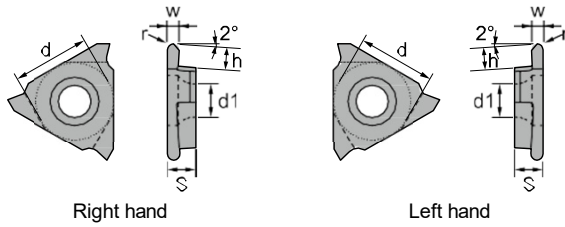

| Order Code | Description        | Dimensions (mm) |     |       |      |       |     | Max Depth of Cut |      | Working Material |   |   |   |   |   |
|------------|--------------------|-----------------|-----|-------|------|-------|-----|------------------|------|------------------|---|---|---|---|---|
|            |                    | w               | h   | r     | S    | d     | d1  | O.D.             | I.D. | P                | M | K | N | S | H |
| NKB101062  | TGF32R025R IL4025P | 0.50            | 1.4 | 0.25  | 3.18 | 9.525 | 4.4 | 1.2              | 0.8  | •                | • | • |   | ○ | ○ |
| NKB101063  | TGF32L025R IL4025P | 0.50            | 1.4 | 0.25  | 3.18 | 9.525 | 4.4 | 1.2              | 0.8  | •                | • | • |   | ○ | ○ |
| NKB101064  | TGF32R037R IL4025P | 0.75            | 2.5 | 0.375 | 3.18 | 9.525 | 4.4 | 2.0              | 1.5  | •                | • | • |   | ○ | ○ |
| NKB101065  | TGF32L037R IL4025P | 0.75            | 2.5 | 0.375 | 3.18 | 9.525 | 4.4 | 2.0              | 1.5  | •                | • | • |   | ○ | ○ |
| NKB101066  | TGF32R050R IL4025P | 1.00            | 2.5 | 0.5   | 3.18 | 9.525 | 4.4 | 2.0              | 1.5  | •                | • | • |   | ○ | ○ |
| NKB101067  | TGF32L050R IL4025P | 1.00            | 2.5 | 0.5   | 3.18 | 9.525 | 4.4 | 2.0              | 1.5  | •                | • | • |   | ○ | ○ |
| NKB101068  | TGF32R062R IL4025P | 1.25            | 2.5 | 0.625 | 3.18 | 9.525 | 4.4 | 2.0              | 1.5  | •                | • | • |   | ○ | ○ |
| NKB101069  | TGF32L062R IL4025P | 1.25            | 2.5 | 0.625 | 3.18 | 9.525 | 4.4 | 2.0              | 1.5  | •                | • | • |   | ○ | ○ |
| NKB101070  | TGF32R075R IL4025P | 1.50            | 2.5 | 0.75  | 3.18 | 9.525 | 4.4 | 2.0              | 1.5  | •                | • | • |   | ○ | ○ |
| NKB101071  | TGF32L075R IL4025P | 1.50            | 2.5 | 0.75  | 3.18 | 9.525 | 4.4 | 2.0              | 1.5  | •                | • | • |   | ○ | ○ |

※ To choose IL90U(uncoating) for **N** material machining.

**TGL Shallow Grooving Tools (Laydown, Depth < 2.5mm)**

**Tool Holder Specifications**

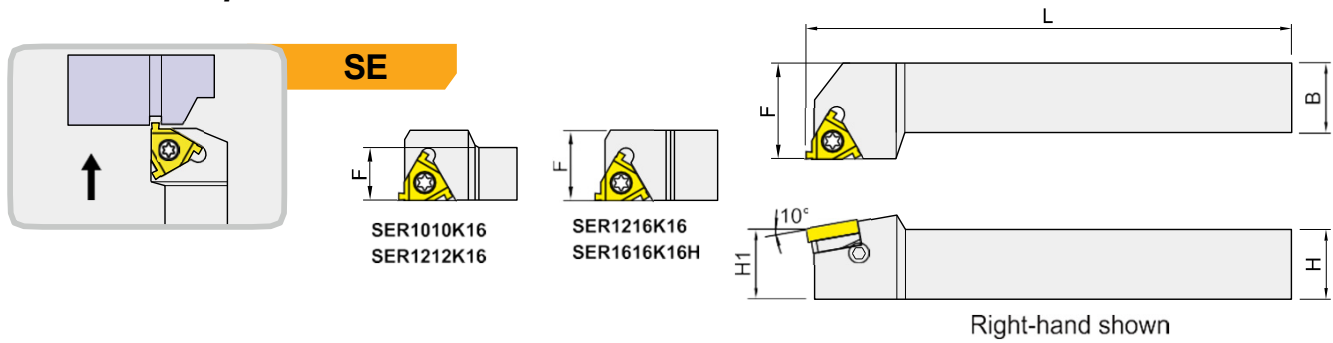

| Order Code | Description | Dimensions (mm) |    |     |    | Insert                   | Spare parts |
|------------|-------------|-----------------|----|-----|----|--------------------------|-------------|
|            |             | H(H1)           | B  | L   | F  |                          |             |
| NKB101198  | SER1216K16  | 12              | 16 | 125 | 16 | TGL16ER<br>or<br>TGL16EL | ①           |
| NKB101199  | SER1216K16  |                 |    |     |    |                          |             |
| NKB101200  | SER1010K16H | 10              | 10 | 125 | 10 |                          |             |
| NKB101201  | SER1010K16H |                 |    |     |    |                          |             |
| NKB101202  | SER1212K16H | 12              | 12 | 125 | 12 |                          |             |
| NKB101203  | SER1212K16H |                 |    |     |    |                          |             |
| NKB101204  | SER1616K16H | 16              | 16 | 125 | 16 |                          |             |
| NKB101205  | SER1616K16H |                 |    |     |    |                          |             |
| NKB101206  | SER1616K16  | 16              | 16 | 125 | 20 |                          |             |
| NKB101207  | SER1616K16  |                 |    |     |    |                          |             |
| NKB101208  | SER2020K16  | 20              | 20 | 125 | 25 |                          | ②           |
| NKB101209  | SER2020K16  |                 |    |     |    |                          |             |
| NKB101210  | SER2525M16  | 25              | 25 | 150 | 32 |                          |             |
| NKB101211  | SER2525M16  |                 |    |     |    |                          |             |
| NKB101212  | SER3232P16  | 32              | 32 | 170 | 40 |                          |             |
| NKB101213  | SER3232P16  |                 |    |     |    |                          |             |

| Spare parts | Screw    | Shim             | Screw   | Wrench | Wrench |
|-------------|----------|------------------|---------|--------|--------|
| ①           | IMS3509A | -                | -       | -      | ITK15  |
| ②           | IMS3512A | IGXN16 or IGXE16 | IHTM309 | IPL25  | ITK15  |

※ SER right hand tools shim is IGXE16, SEL left hand tools shim is IGXN16.

**TGL Shallow Grooving Tools (Laydown, Depth < 2.5mm)**

**Tool Holder Specifications**

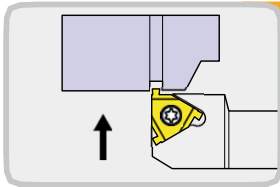

**SKE**

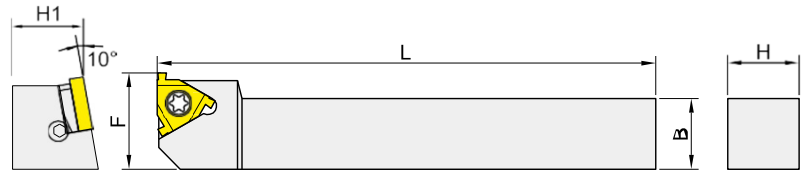

Right-hand shown

| Order Code | Description | Dimensions (mm) |    |     |    | Insert                   | Spare parts |
|------------|-------------|-----------------|----|-----|----|--------------------------|-------------|
|            |             | H(H1)           | B  | L   | F  |                          |             |
| NKB101214  | SKER1212K16 | 12              | 12 | 125 | 18 | TGL16ER<br>or<br>TGL16EL | ①           |
| NKB101215  | SKEL1212K16 |                 |    |     |    |                          |             |
| NKB101216  | SKER1616K16 | 16              | 16 | 125 | 22 |                          | ②           |
| NKB101217  | SKEL1616K16 |                 |    |     |    |                          |             |
| NKB101218  | SKER2020K16 | 20              | 20 | 125 | 27 |                          |             |
| NKB101219  | SKEL2020K16 |                 |    |     |    |                          |             |
| NKB101220  | SKER2525M16 | 25              | 25 | 150 | 34 |                          |             |
| NKB101221  | SKEL2525M16 |                 |    |     |    |                          |             |

| Spare parts | Screw<br> | Shim<br>         | Screw<br> | Wrench<br> | Wrench<br> |
|-------------|-----------|------------------|-----------|------------|------------|
| ①           | IMS3509A  | -                | -         | -          | ITK15      |
| ②           | IMS3512A  | IGXN16 or IGXE16 | IHTM309   | IPL25      | ITK15      |

\* SKER right hand tools shim is IGXE16, SKEL left hand tools shim is IGXN16.

**SE Shallow Grooving Tools (Laydown, Depth < 2.5mm)**



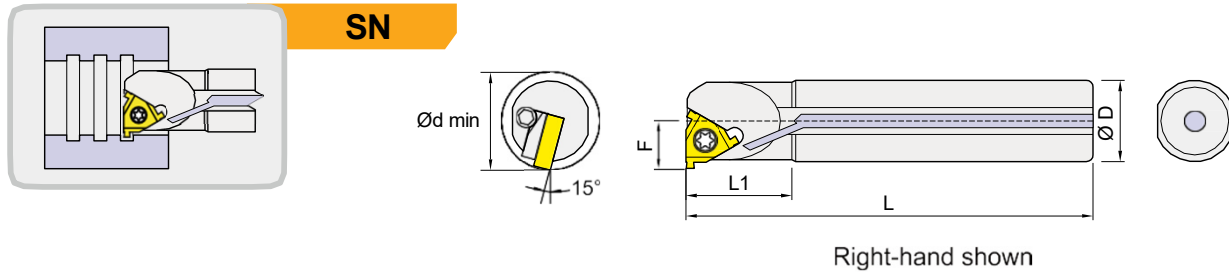

**Tool Holder Specifications**



| Order Code | Description    | Dimensions (mm) |     |    |      |       | Coolant | Insert                   | Spare parts |   |                          |   |
|------------|----------------|-----------------|-----|----|------|-------|---------|--------------------------|-------------|---|--------------------------|---|
|            |                | D               | L   | L1 | F    | d min |         |                          |             |   |                          |   |
| NKB101222  | SNR0010K11S10  | 10              | 125 | 22 | 6.5  | 13    | •       | TGL11IR<br>or<br>TGL11IL | ①           |   |                          |   |
| NKB101223  | SNL0010K11S10  |                 |     |    |      |       |         |                          |             |   |                          |   |
| NKB101224  | SNR0012M11S12  | 12              | 150 | 26 | 8    | 16    |         |                          |             |   |                          |   |
| NKB101225  | SNL0012M11S12  |                 |     |    |      |       |         |                          |             |   |                          |   |
| NKB101226  | SNRA0010K11S10 | 10              | 125 | 22 | 6.5  | 13    |         |                          |             | • | TGL16IR<br>or<br>TGL16IL | ② |
| NKB101227  | SNLA0010K11S10 |                 |     |    |      |       |         |                          |             |   |                          |   |
| NKB101228  | SNRA0012M11S12 | 12              | 150 | 26 | 8    | 16    |         |                          |             |   |                          |   |
| NKB101229  | SNLA0012M11S12 |                 |     |    |      |       |         |                          |             |   |                          |   |
| NKB101230  | SNR0016Q16     | 16              | 180 | 36 | 10   | 19    |         |                          |             |   |                          |   |
| NKB101231  | SNL0016Q16     |                 |     |    |      |       |         |                          |             |   |                          |   |
| NKB101232  | SNR0020R16     | 20              | 200 | 40 | 12   | 24    |         |                          |             |   |                          |   |
| NKB101233  | SNL0020R16     |                 |     |    |      |       |         |                          |             |   |                          |   |
| NKB101234  | SNR0025R16     | 25              | 200 | 45 | 14.5 | 29    | •       | TGL16IR<br>or<br>TGL16IL | ③           |   |                          |   |
| NKB101235  | SNL0025R16     |                 |     |    |      |       |         |                          |             |   |                          |   |
| NKB101236  | SNR0032S16     | 32              | 250 | 45 | 18.5 | 36    |         |                          |             |   |                          |   |
| NKB101237  | SNL0032S16     |                 |     |    |      |       |         |                          |             |   |                          |   |
| NKB101238  | SNRA0016Q16    | 16              | 180 | 36 | 10   | 19    |         |                          |             | • | TGL16IR<br>or<br>TGL16IL | ② |
| NKB101239  | SNLA0016Q16    |                 |     |    |      |       |         |                          |             |   |                          |   |
| NKB101240  | SNRA0020R16    | 20              | 200 | 40 | 12   | 24    |         |                          |             |   |                          |   |
| NKB101241  | SNLA0020R16    |                 |     |    |      |       |         |                          |             |   |                          |   |
| NKB101242  | SNRA0025R16    | 25              | 200 | 45 | 14.5 | 29    |         |                          |             |   |                          |   |
| NKB101243  | SNLA0025R16    |                 |     |    |      |       |         |                          |             |   |                          |   |
| NKB101244  | SNRA0032S16    | 32              | 250 | 45 | 18.5 | 36    |         |                          |             |   |                          |   |
| NKB101245  | SNLA0032S16    |                 |     |    |      |       |         |                          |             |   |                          |   |



**SE Shallow Grooving Tools (Laydown, Depth < 2.5mm)**

| Spare parts | Screw<br> | Wrench<br> | Shim<br> | Screw<br> | Wrench<br> |
|-------------|--------------------------------------------------------------------------------------------|---------------------------------------------------------------------------------------------|-------------------------------------------------------------------------------------------|----------------------------------------------------------------------------------------------|-----------------------------------------------------------------------------------------------|
| ①           | IMS2507G                                                                                   | ITK08                                                                                       | -                                                                                         | -                                                                                            | -                                                                                             |
| ②           | IMS3509A                                                                                   | ITK15                                                                                       | -                                                                                         | -                                                                                            | -                                                                                             |
| ③           | IMS3512A                                                                                   | ITK15                                                                                       | IGXN16 or IGXE16                                                                          | IHTM309                                                                                      | IPL25                                                                                         |

※ SNR right hand tools shim is IGXN16, SNL left hand tools shim is IGXE16.

**Recommended Cutting Conditions**

| Working Material           | Vc (m/min) | fr (mm/rev) |
|----------------------------|------------|-------------|
| Carbon Steel / Alloy Steel | 50 ~ 200   | 0.02 ~ 0.10 |
| Stainless Steel            | 50 ~ 200   | 0.02 ~ 0.10 |
| Cast Iron                  | 50 ~ 200   | 0.02 ~ 0.10 |
| Aluminum Alloy             | 200 ~ 300  | 0.05 ~ 0.15 |
| High Temperature Alloy     | 80 ~ 120   | 0.03 ~ 0.07 |
| Hardened Steel             | 80 ~ 120   | 0.03 ~ 0.07 |

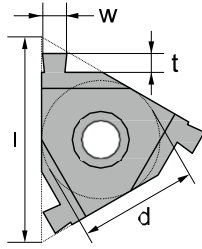
**SKE Shallow Grooving Tools (Laydown, Depth < 2.5mm)**
**Insert Description**

※ Same insert can be used for external right hand and internal left hand.

| Order Code | Description        | Dimensions (mm) |    |            |      | Working Material |   |   |   |   |   |
|------------|--------------------|-----------------|----|------------|------|------------------|---|---|---|---|---|
|            |                    | d               | l  | W<br>±0.02 | t    | P                | M | K | N | S | H |
| NKB101072  | TGL11ER050 IL4025P | 1/4             | 11 | 0.50       | 1.4  | •                | • | • |   | ○ | ○ |
| NKB101073  | TGL11IL050 IL4025P | 1/4             | 11 | 0.50       | 1.4  | •                | • | • |   | ○ | ○ |
| NKB101074  | TGL11ER060 IL4025P | 1/4             | 11 | 0.60       | 1.4  | •                | • | • |   | ○ | ○ |
| NKB101075  | TGL11IL060 IL4025P | 1/4             | 11 | 0.60       | 1.4  | •                | • | • |   | ○ | ○ |
| NKB101076  | TGL11ER070 IL4025P | 1/4             | 11 | 0.70       | 1.4  | •                | • | • |   | ○ | ○ |
| NKB101077  | TGL11IL070 IL4025P | 1/4             | 11 | 0.70       | 1.4  | •                | • | • |   | ○ | ○ |
| NKB101078  | TGL11ER080 IL4025P | 1/4             | 11 | 0.80       | 1.4  | •                | • | • |   | ○ | ○ |
| NKB101079  | TGL11IL080 IL4025P | 1/4             | 11 | 0.80       | 1.4  | •                | • | • |   | ○ | ○ |
| NKB101080  | TGL11ER100 IL4025P | 1/4             | 11 | 1.00       | 1.4  | •                | • | • |   | ○ | ○ |
| NKB101081  | TGL11IL100 IL4025P | 1/4             | 11 | 1.00       | 1.4  | •                | • | • |   | ○ | ○ |
| NKB101082  | TGL11ER120 IL4025P | 1/4             | 11 | 1.20       | 1.4  | •                | • | • |   | ○ | ○ |
| NKB101083  | TGL11IL120 IL4025P | 1/4             | 11 | 1.20       | 1.4  | •                | • | • |   | ○ | ○ |
| NKB101084  | TGL16ER050 IL4025P | 3/8             | 16 | 0.50       | 1.4  | •                | • | • |   | ○ | ○ |
| NKB101085  | TGL16IL050 IL4025P | 3/8             | 16 | 0.50       | 1.4  | •                | • | • |   | ○ | ○ |
| NKB101086  | TGL16ER100 IL4025P | 3/8             | 16 | 1.00       | 1.4  | •                | • | • |   | ○ | ○ |
| NKB101087  | TGL16IL100 IL4025P | 3/8             | 16 | 1.00       | 1.4  | •                | • | • |   | ○ | ○ |
| NKB101088  | TGL16ER120 IL4025P | 3/8             | 16 | 1.20       | 1.6  | •                | • | • |   | ○ | ○ |
| NKB101089  | TGL16IL120 IL4025P | 3/8             | 16 | 1.20       | 1.6  | •                | • | • |   | ○ | ○ |
| NKB101090  | TGL16ER140 IL4025P | 3/8             | 16 | 1.40       | 1.8  | •                | • | • |   | ○ | ○ |
| NKB101091  | TGL16IL140 IL4025P | 3/8             | 16 | 1.40       | 1.8  | •                | • | • |   | ○ | ○ |
| NKB101092  | TGL16ER170 IL4025P | 3/8             | 16 | 1.70       | 2.0  | •                | • | • |   | ○ | ○ |
| NKB101093  | TGL16IL170 IL4025P | 3/8             | 16 | 1.70       | 2.0  | •                | • | • |   | ○ | ○ |
| NKB101094  | TGL16ER195 IL4025P | 3/8             | 16 | 1.95       | 2.0  | •                | • | • |   | ○ | ○ |
| NKB101095  | TGL16IL195 IL4025P | 3/8             | 16 | 1.95       | 2.0  | •                | • | • |   | ○ | ○ |
| NKB101096  | TGL16ER225 IL4025P | 3/8             | 16 | 2.25       | 2.25 | •                | • | • |   | ○ | ○ |
| NKB101097  | TGL16IL225 IL4025P | 3/8             | 16 | 2.25       | 2.25 | •                | • | • |   | ○ | ○ |

※ To choose IL90U(uncoating) for **N** material machining.

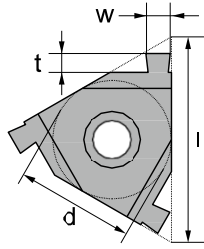
**SN Shallow Grooving Tools (Laydown, Depth < 2.5mm)**
**Insert Description**

※ Same insert can be used for internal right hand and external left hand.

| Order Code | Description        | Dimensions (mm) |    |            |      | Working Material |   |   |   |   |   |
|------------|--------------------|-----------------|----|------------|------|------------------|---|---|---|---|---|
|            |                    | d               | l  | w<br>±0.02 | t    | P                | M | K | N | S | H |
| NKB101098  | TGL11IR050 IL4025P | 1/4             | 11 | 0.50       | 1.4  | •                | • | • |   | ○ | ○ |
| NKB101099  | TGL11EL050 IL4025P | 1/4             | 11 | 0.50       | 1.4  | •                | • | • |   | ○ | ○ |
| NKB101100  | TGL11IR060 IL4025P | 1/4             | 11 | 0.60       | 1.4  | •                | • | • |   | ○ | ○ |
| NKB101101  | TGL11EL060 IL4025P | 1/4             | 11 | 0.60       | 1.4  | •                | • | • |   | ○ | ○ |
| NKB101102  | TGL11IR070 IL4025P | 1/4             | 11 | 0.70       | 1.4  | •                | • | • |   | ○ | ○ |
| NKB101103  | TGL11EL070 IL4025P | 1/4             | 11 | 0.70       | 1.4  | •                | • | • |   | ○ | ○ |
| NKB101104  | TGL11IR080 IL4025P | 1/4             | 11 | 0.80       | 1.4  | •                | • | • |   | ○ | ○ |
| NKB101105  | TGL11EL080 IL4025P | 1/4             | 11 | 0.80       | 1.4  | •                | • | • |   | ○ | ○ |
| NKB101106  | TGL11IR100 IL4025P | 1/4             | 11 | 1.00       | 1.4  | •                | • | • |   | ○ | ○ |
| NKB101107  | TGL11EL100 IL4025P | 1/4             | 11 | 1.00       | 1.4  | •                | • | • |   | ○ | ○ |
| NKB101108  | TGL11IR120 IL4025P | 1/4             | 11 | 1.20       | 1.4  | •                | • | • |   | ○ | ○ |
| NKB101109  | TGL11EL120 IL4025P | 1/4             | 11 | 1.20       | 1.4  | •                | • | • |   | ○ | ○ |
| NKB101110  | TGL16IR050 IL4025P | 3/8             | 16 | 0.50       | 1.4  | •                | • | • |   | ○ | ○ |
| NKB101111  | TGL16EL050 IL4025P | 3/8             | 16 | 0.50       | 1.4  | •                | • | • |   | ○ | ○ |
| NKB101112  | TGL16IR100 IL4025P | 3/8             | 16 | 1.00       | 1.4  | •                | • | • |   | ○ | ○ |
| NKB101113  | TGL16EL100 IL4025P | 3/8             | 16 | 1.00       | 1.4  | •                | • | • |   | ○ | ○ |
| NKB101114  | TGL16IR120 IL4025P | 3/8             | 16 | 1.20       | 1.6  | •                | • | • |   | ○ | ○ |
| NKB101115  | TGL16EL120 IL4025P | 3/8             | 16 | 1.20       | 1.6  | •                | • | • |   | ○ | ○ |
| NKB101116  | TGL16IR140 IL4025P | 3/8             | 16 | 1.40       | 1.8  | •                | • | • |   | ○ | ○ |
| NKB101117  | TGL16EL140 IL4025P | 3/8             | 16 | 1.40       | 1.8  | •                | • | • |   | ○ | ○ |
| NKB101118  | TGL16IR170 IL4025P | 3/8             | 16 | 1.70       | 2.0  | •                | • | • |   | ○ | ○ |
| NKB101119  | TGL16EL170 IL4025P | 3/8             | 16 | 1.70       | 2.0  | •                | • | • |   | ○ | ○ |
| NKB101120  | TGL16IR195 IL4025P | 3/8             | 16 | 1.95       | 2.0  | •                | • | • |   | ○ | ○ |
| NKB101121  | TGL16EL195 IL4025P | 3/8             | 16 | 1.95       | 2.0  | •                | • | • |   | ○ | ○ |
| NKB101122  | TGL16IR225 IL4025P | 3/8             | 16 | 2.25       | 2.25 | •                | • | • |   | ○ | ○ |
| NKB101123  | TGL16EL225 IL4025P | 3/8             | 16 | 2.25       | 2.25 | •                | • | • |   | ○ | ○ |

※ To choose IL90U(uncoating) for **N** material machining.

**SGIH Parting Tools (Depth < 40mm)**

**Tool Holder Specifications**

**SGIH**

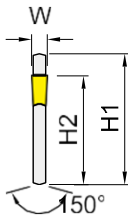
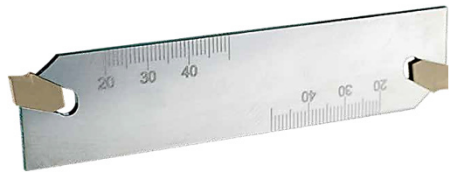

| Order code | Description | Dimensions (mm) |      |     |     | Insert   | Tool Block   | Wrench |
|------------|-------------|-----------------|------|-----|-----|----------|--------------|--------|
|            |             | H1              | H2   | L   | W   |          |              |        |
| NKB101246  | SGIH26-2    | 26              | 21.4 | 110 | 2.2 | TGTN0220 | ISGTBU...-26 | IESG-1 |
| NKB101247  | SGIH26-3    | 26              | 21.4 | 110 | 3.1 | TGTN0310 |              |        |
| NKB101248  | SGIH26-4    | 26              | 21.4 | 110 | 4.1 | TGTN0410 |              |        |
| NKB101249  | SGIH32-2    | 32              | 25   | 150 | 2.2 | TGTN0220 | ISGTBU...-32 |        |
| NKB101250  | SGIH32-3    | 32              | 25   | 150 | 3.1 | TGTN0310 |              |        |
| NKB101251  | SGIH32-4    | 32              | 25   | 150 | 4.1 | TGTN0410 |              |        |

**SGTBU**

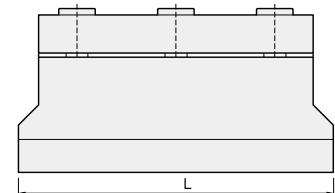
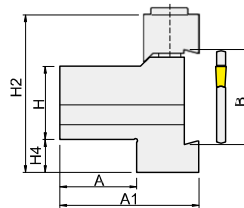

| Order code | Description | Dimensions (mm) |    |    |    |     |    |    | Screw   | Wrench | BLADE     |
|------------|-------------|-----------------|----|----|----|-----|----|----|---------|--------|-----------|
|            |             | H               | B  | A  | A1 | L   | H2 | H4 |         |        |           |
| NKB101252  | SGTBU20-26  | 20              | 26 | 21 | 38 | 86  | 43 | 9  | IHTM630 | IPL50  | ISGIH26-3 |
| NKB101253  | SGTBU25-26  | 25              | 26 | 23 | 40 | 86  | 43 | 4  |         |        |           |
| NKB101254  | SGTBU20-32  | 20              | 32 | 21 | 40 | 110 | 50 | 13 |         |        | ISGIH32-3 |
| NKB101255  | SGTBU25-32  | 25              | 32 | 23 | 42 | 110 | 50 | 8  |         |        |           |

**SGTHR**

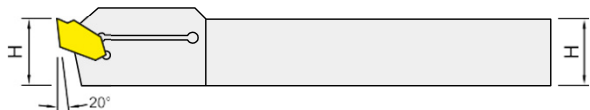
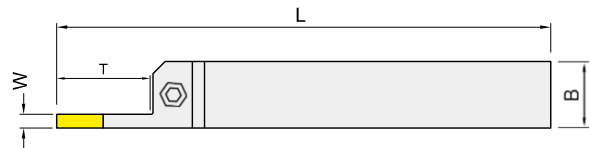

| Order code | Description | Dimensions (mm) |    |     |   |    | Insert   | Screw   | Wrench |
|------------|-------------|-----------------|----|-----|---|----|----------|---------|--------|
|            |             | H               | B  | L   | W | T  |          |         |        |
| NKB101256  | SGTHR16162  | 16              | 16 | 110 | 2 | 16 | TGTN0220 | IHTM521 | IPL40  |
| NKB101257  | SGTHR20202  | 20              | 20 | 125 | 2 | 18 |          |         |        |
| NKB101258  | SGTHR20203  | 20              | 20 | 125 | 3 | 20 | TGTN0310 | IHTM625 | IPL50  |
| NKB101259  | SGTHR25253  | 25              | 25 | 150 | 3 | 25 |          |         |        |
| NKB101260  | SGTHR25254  | 25              | 25 | 150 | 4 | 30 | TGTN0410 | IHTM625 | IPL50  |



**IL PRECISION TECHNOLOGY**